



IMP 02-01

DISCOVER
MYSPYDER





I - MYGALE	3
Engineered to win	4
35 years of history	5
II – MYGALE MYSPYDER	6
An undeniable affiliation	7
Concept	8
III – WHY CHOOSE MYGALE	14
Choose the MYGALE MYSPYDER	16



1 MYGALE

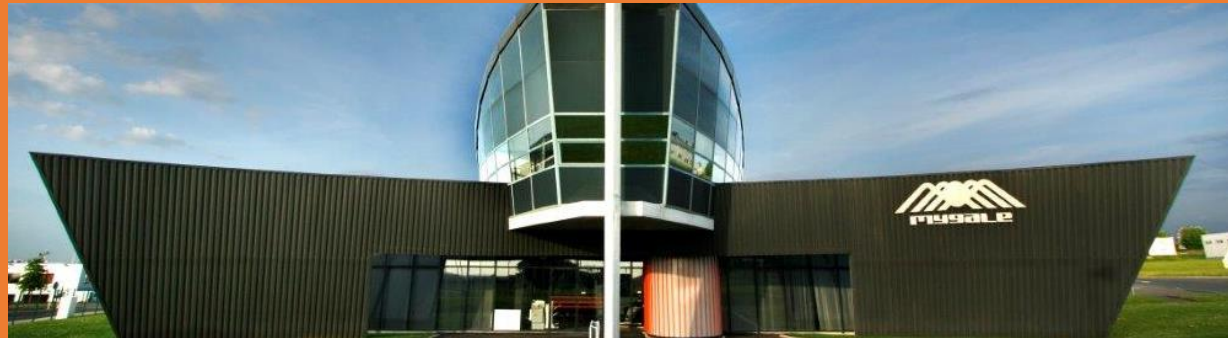

ENGINEERED TO WIN



1 266 cars produced



1 297 victories on 5 continents



29 F1 drivers
(+ **23** F1 test drivers)



7 F1 world champion titles
120 Grand Prix victories



MYGALE - 35 YEARS OF HISTORY



- 1989 Bertrand DECOSTER decides to build the 1st French **Formula Ford**
- 1993 Mygale 1st win in Formula Ford in Nogaro
- 1995 **Formula Renault Mygale** – French and European Champion
- 2000 Mygale moved to the Technopole of the Nevers Magny-Cours circuit
- 2002 **Formula BMW**
- 2007 **Formula 3 FIA** and **Peugeot spider**
- 2012 Italy Formula 3 Champion
- 2014 **FIA Formula 4**
- 2018 **Formula 3 Regional FIA**
- 2019 **Mygale MySpyder**
- 2020 **Crosscar XC02**
- 2021 **Formula 4 FIA generation**
- 2023 **Crosscar XC04**
- 2024 **FIA Formula Regional**



Formule Ford



Formule Renault



Formule BMW



Peugeot Spider



Formule 3



Formule 4



Formule 3 Regionale



XC Cross Car



MySpyder



Formule 4 Gen2



2



MYGALE
MYSPYDER



AN UNDENIABLE FILIATION



MYGALE has capitalized on its experience of circuit racing to offer a two-seater sports car with a modern and daring design with excellent value for money

Leisure car or serious option for more experienced amateur pilots, the MySpyder is intended for trackdays, driving schools or competition on proto stages

Top performance thanks to its excellent weight / power ratio with a YAMAHA R1 engine

Flexibility of use: between driving schools and amateur pilots with our clamping range between 100 and 200 hp



CONCEPT - Specifications



REGULATIONS / SAFETY	Compliant to technical regulation FIA Group E, category II-SH Roll cage fully homologated following the FIA regulation of the safety cage, side anti-intrusion door bars, front crash box FIA homologated driving seat. 6-point seat belt FIA FT3 30L specification safety fuel tank
DRIVER	1,50m to 1,95 m, 50 to 110 kg
DIMENSIONS / WEIGHT	3'600 mm x 1'800 mm x 1'030 mm Max 650 kg dry weight without driver
CHASSIS	High performance tubular space frame. Steel 25CD4S Aluminum floor
BODYWORK	Glassfibre composite panels Glass laminated windscreen with standard wipers Front lights and turn signals / rear, rain and brake lights
ENGINE	Standard Yamaha 998 cm ³ R1, 100 hp to 200 cv, 112 Nm Wiring loom, electronic controls and dashboard Yamaha YEC.
TRANSMISSION	Standard Yamaha R1 gearbox with constant grip. 6 speeds and electrical reverse gear. Paddle shift Chaine drive/ Quaife ATB waterproof differential
SUSPENSION	Not adjustable KONI dampers. Cast aluminium upright. Double wishbone, pushrod and rocker. Front and rear anti roll-bar
STEERING	Non assisted production car derived steering rack. Height and front/rear adjustable steering wheel
COLUMN	With quick release steering wheel and collapsible column.
BRAKES	Production caliper and non ventilated disc
OPTIMISATION	Equipped with headlights and muffler (> 95db) for night use



Chain drive

Advantages :

- Economic
- Simple tension adjustment
- Reliability

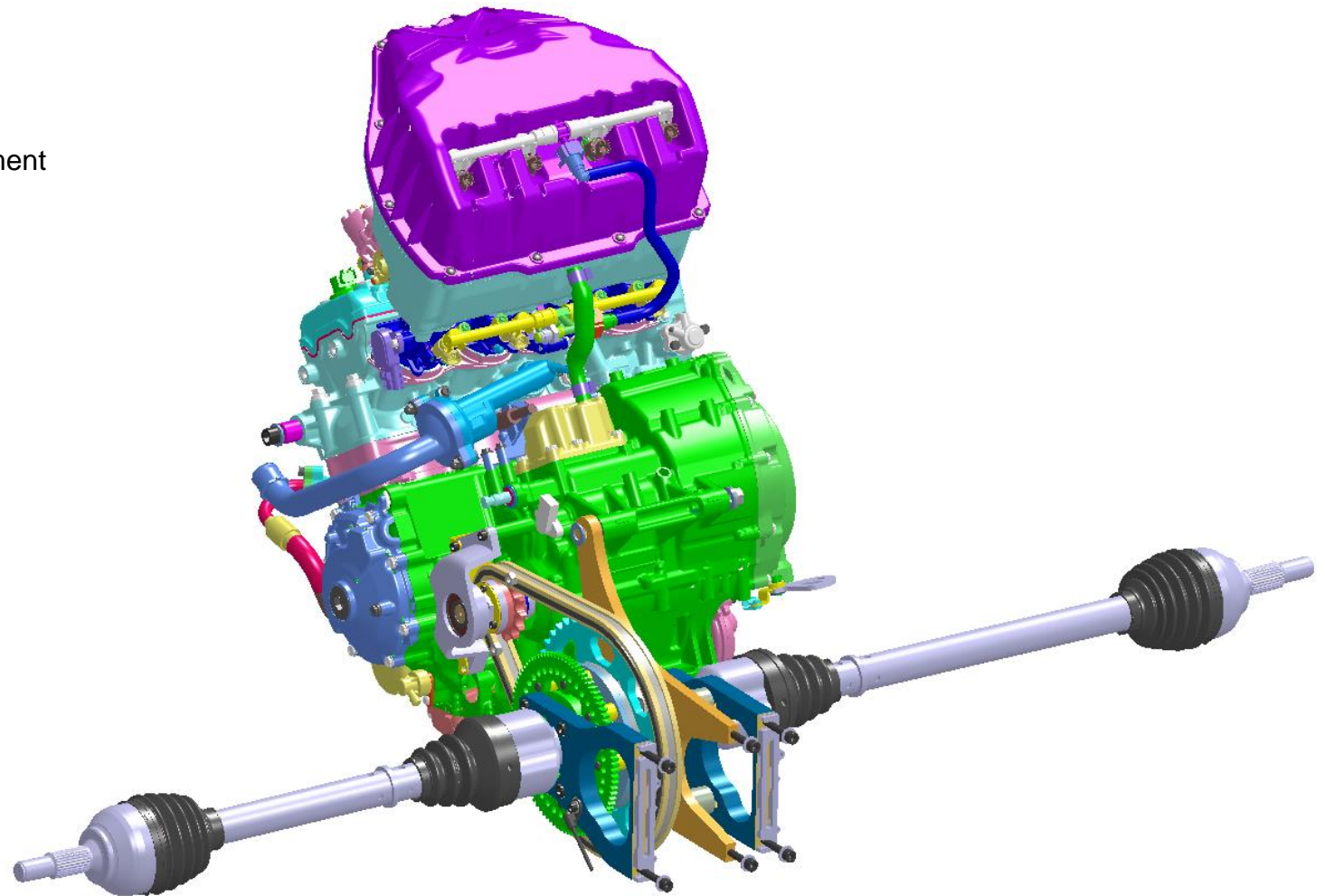

CONCEPT - Design



- Bodywork : 11 elements
- Strong and unique visual identity
- Fixed aerodynamic package with integrated front splitter and rear diffuser
- Fixed rear wing and shark fin-shaped engine hood
- Set-up adjustability, springs, front and rear anti-roll-bar
- Several colors available
- Addition of doors possible
- Many different type of possible tyres (both 17" and 16")

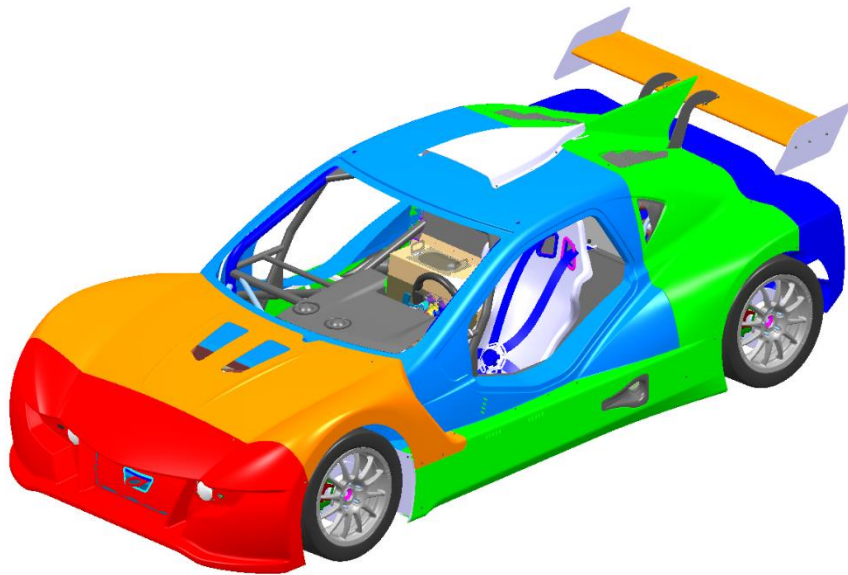
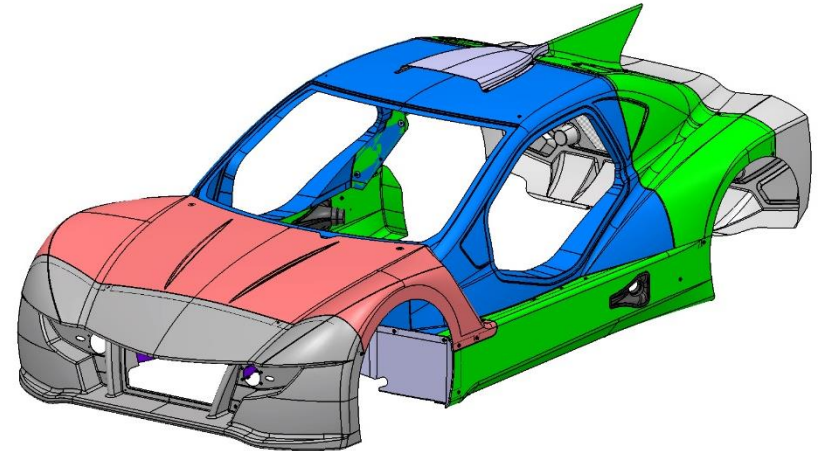

CONCEPT - Design

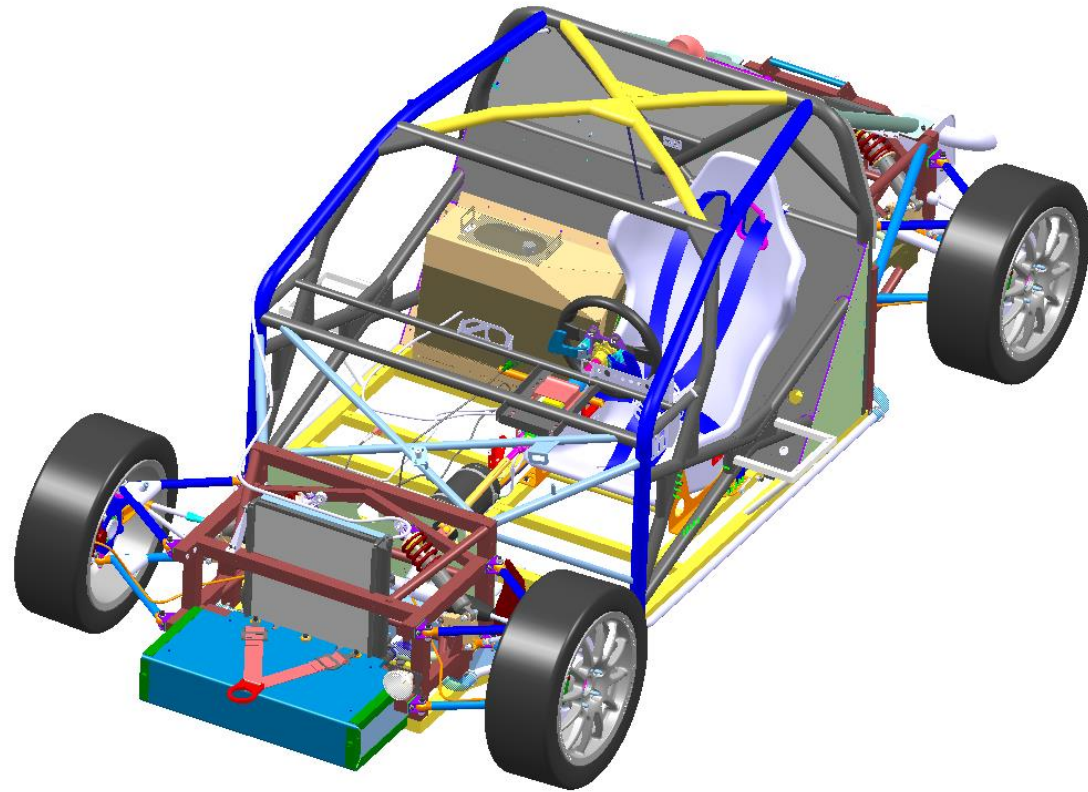
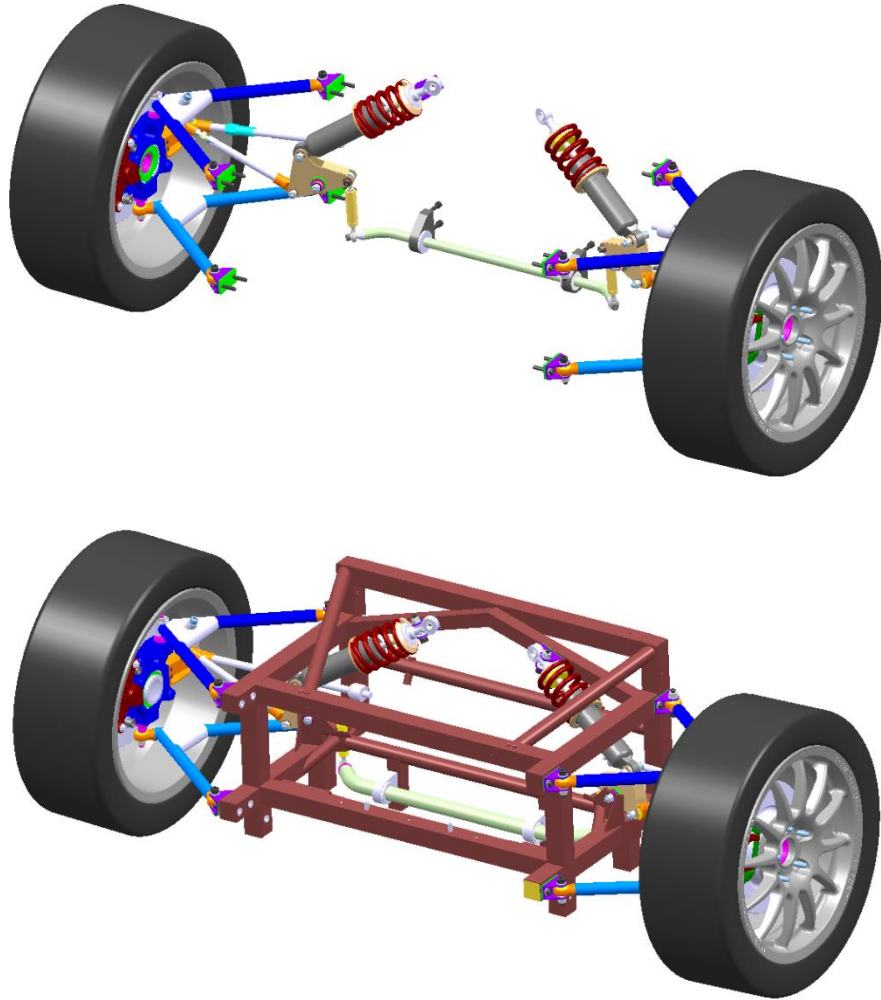

CONCEPT - Design

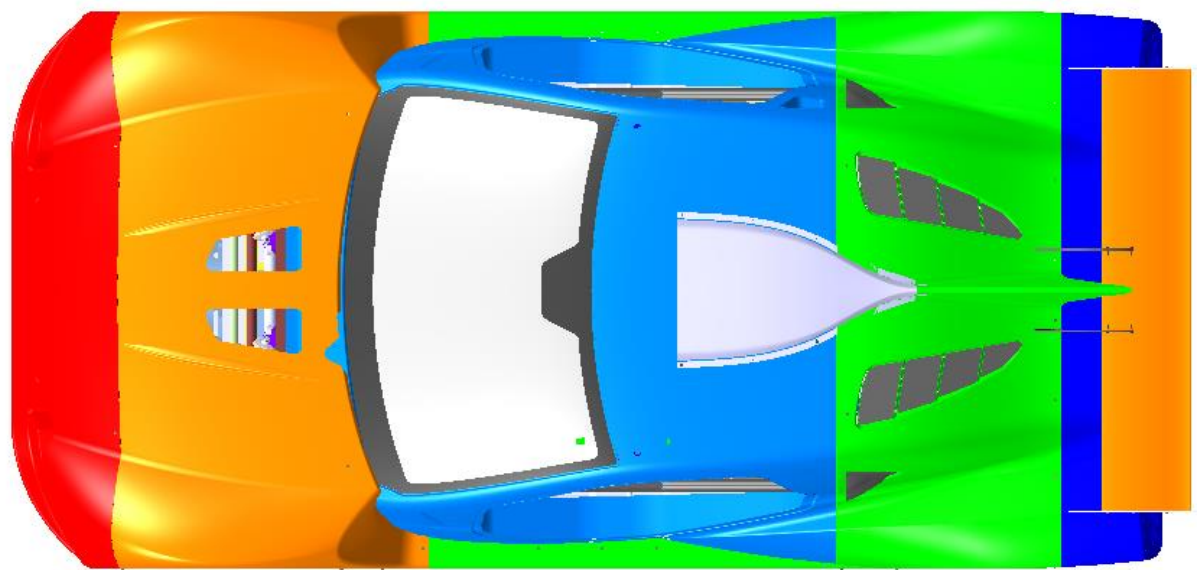
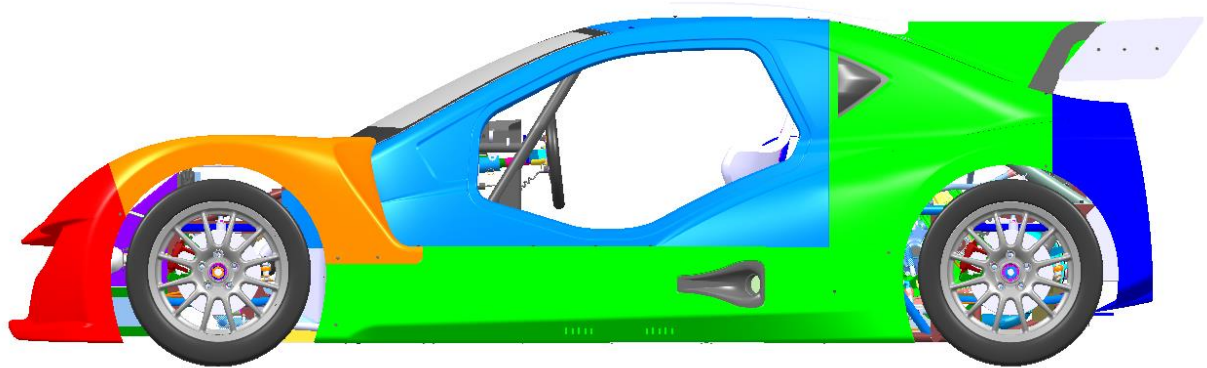
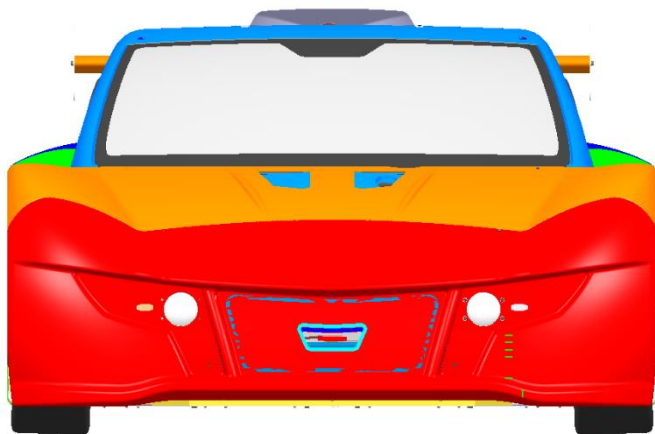

CONCEPT - Performance



Magny-Cours « Club » track (2,53 km)

- Formula 4 Mygale 1.13.8
- MySpyder version 200cv 1.17.34
- Mercedes AMG SLS 1.23.50
- Ferrari California 1.23.65
- Porsche Cayman 718 1.24.21
- Alpine A110 2019 1.24.62

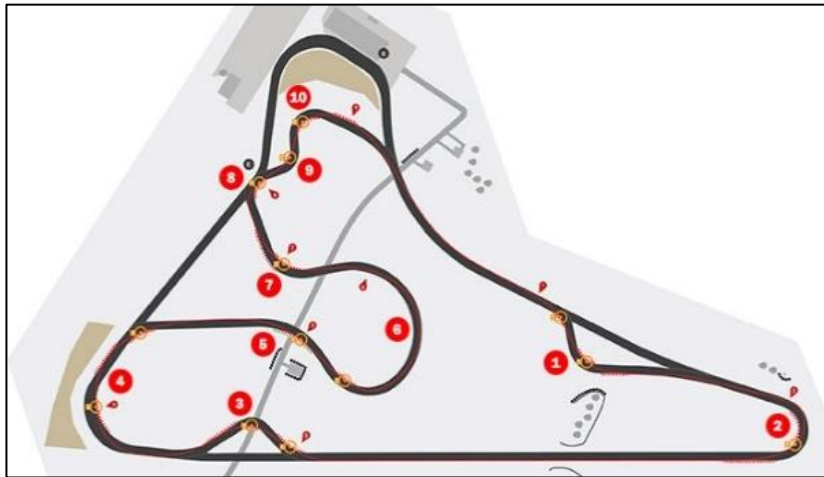

3



Why Choose MYGALE



WHY CHOOSE MYGALE



Mygale's FIA expertise

- ↳ Direct partner of the FIA for more than 6 years
- ↳ Leading partner in **FIA homologated F4 and F3 chassis** (Argentina, South East Asia, Australia, China, Denmark, United States, France, Mexico, UK)

EXCLUSIVE partnership with Yamaha

- ↳ **Yamaha engine and accessories supplier**

A strong GLOBAL RECORD in detection series

- ↳ **Having been BMW worldwide partner for more than 12 years with the BMW Formula**

A strict 10 years old QUALITY CONTROL POLICY

- ↳ **Bureau Veritas Certification ISO 9001 v2015**



CHOOSE MYSPYDER MYGALE



1. Limited complexity for maximum reliability over years of use
 - Chassis repairable by teams (excluding security structures)
 - Excellent vehicle repairability
 - Minimal technical complexity
 - Reliable Yamaha engines
2. Easy assistance from a first-class F4 car manufacturer near you
3. Much lower maintenance cost compared to other trackdays vehicles
4. Easy customization of the car according to your own specificities



Contact:

Bertrand DECOSTER
CEO

MYGALE
Technopole
58470 Magny-Cours

+33 3 86 21 86 21

+33 6 07 37 65 41

decoster@mygale.fr

